

SECTION V

Purpose and Scope

This drawing is intended to serve as a guide for the installation of customer-owned service poles as specified in General Order No. 95 *Rules for Overhead Electric Line Construction* of the California Public Utilities Commission and in minor deviations from GO-95 which have been authorized by the Commission. Equipment installed on service poles as shown on this drawing will also meet the requirements of the State Building Standards Electrical Regulations. These requirements have been established by the State in the interest of safety to the public and to workers and are applicable to all customer-owned service poles. Alameda Municipal Power (AMP) cannot establish service to poles which do not meet these minimum requirements. The maintenance of customer-owned service poles in conformity with these requirements is the sole responsibility of the customer.

Ordinances may include wiring requirements in addition to those shown on this drawing. Consult the electrical inspector for these requirements and for City permits and inspection which is required before service can be connected.

Temporary Service Pole Installation

The use of temporary service poles shall be restricted to installations of a temporary nature such as building construction, temporary sales location, etc., where the period of service is estimated to be one year or less.

Temporary service poles shall be furnished and installed by the customer and must be wooden. The minimum length shall be 20 feet, set four feet in ground. A longer pole may be necessary to provide the required clearance from the ground or to supply the customer's overhead line.

A temporary wood service pole may be rectangular or circular in cross section and shall be solid (not laminated.) Rectangular poles shall have a minimum cross section of 6" x 6" nominal.

The butt of the temporary wood service pole shall at least be painted with copper naphthanate or other approved preservative. However, it is recommended that these poles be full-length treated with a suitable preservative in order to obtain maximum useful life of the pole and to provide increased safety to workers and the public.

Vertical Clearance for Service Poles

- a. Conductors to service poles shall have a minimum ground clearance as follows (also see Figure V-2):
- b. Over center portion of street: 18' minimum (for height over trolleys, railroad tracks, and telephone lines, etc., consult Alameda Municipal Power).
- c. At curb or outer limits of vehicular traffic, 16' minimum.

- d. Over private driveways, lane or other areas accessible to vehicles used for industrial, commercial, or agricultural purposes, 16' minimum.
- e. If required clearances cannot be obtained with a minimum length service pole, the required clearance shall be obtained by using a longer pole.

Service Entrance Conductors

The customers shall furnish, install, and maintain the service entrance wiring and service equipment beyond the point of attachment to Alameda Municipal Power service wires. The service entrance wires shall be continuous and shall be of a size and type which will provide not less than the city minimum standard of safety, as specified in City ordinances or the current issue of the National Electrical Code.

The neutral conductor of a 3-wire 120/240 volt (or 120/208 volt) service shall be securely connected to the neutral terminal of the meter socket and extended through the neutral terminal of the service entrance switch. It shall be continuous (without splice) from the service head to the service entrance switch.

At least 18" of service entrance conductors shall be provided outside the service head.

Service Entrance and Load Side Conduit and Conduit Covering

Service entrance and load side conduit and conduit covering requirements shall comply with the applicable codes and City requirements. G.O. 95 requires that any conduit installed *below* the 8' level on the poles shall be treated as a riser; in which case the conduit shall be either rigid galvanized steel or 2-1/2' minimum diameter sch. 80 pvc.

Exception: Conduit which enters the *top* of an enclosure is considered to be "protected" by the enclosure and need not be treated as a riser unless installed above the 6' or 8' level (whichever height applies) shall be either (1) galvanized rigid steel conduit, (2) rigid aluminum conduit, (3) IMC, or (4) PVC plastic conduit sch. 80. All fittings shall be rain tight. If PVC plastic conduit is used, it need not be covered. If rigid steel or other approved metallic conduit is used it shall be enclosed with either ¼" fiber conduit, 1-1/2" thick wood covering, or PVC U-shaped molding for a minimum distance of 8' below the lowest open service entrance conductor. The covering shall be fastened to the pole at intervals not greater than 3'.

On service poles where rigid steel or IMC is used, a wood block shall be attached directly over the service head. This block is not required on a PVC plastic conduit installation if the conduits do not terminate in grounded terminals or terminal fittings. Refer to Figure V-3.

All conduit fittings shall be rain tight.

Water pipe and fittings are not permitted for use as electrical conduit.

Service Entrance Switch

Main switch, receptacles, and other equipment on load side of the meter shall be of weatherproof enclosures. Such equipment must comply with City ordinances and must also comply with the State building standards – electrical regulations. The switch cover shall be locked if the enclosure contains exposed live parts.

Grounding

The customer shall be responsible for bonding and grounding all exposed non-current-carrying metal parts. Grounding shall be in accordance with NEC and City ordinances except that the grounding wire shall be protected against mechanical damage by rigid steel conduit, or armored copper ground wire may be used.

Pole Location

Poles shall be located so that the required vertical clearances can be obtained. A service pole shall not be located less than 10' from the surface of an Alameda Municipal Power pole, or within 10' from the surface of an Alameda Municipal Power line. The maximum span length of a service drop to a temporary pole shall be 100'.

Guying or Bracing

Where conductors cross a street or road, customer's pole shall be guyed or braced against pull of conductors as follows:

- a. Temporary poles: Wood braces or anchor guys – brace shall not be smaller than 2" x 4" timber and shall be securely bolted to the pole. Refer to Figure V-2.

Metering Requirements

Meters will be furnished by Alameda Municipal Power.

For residential installations, meter sockets without test bypass facilities shall be furnished, installed, and wired by the customer.

For commercial and industrial applications, meter sockets with Alameda Municipal Power--approved test bypass facilities shall be furnished, installed, and wired by the customer. Excepted from this test-bypass requirement are single-phase installations with a standard delivery voltage less than 300 volts and a meter switch rating of 200 amperes or smaller where short interruptions of service are acceptable to the customer for testing and maintenance of the meter by Alameda Municipal Power.

Alameda Municipal Power (AMP)
2000 Grand Street
Alameda, CA 94501
(510) 748-3901

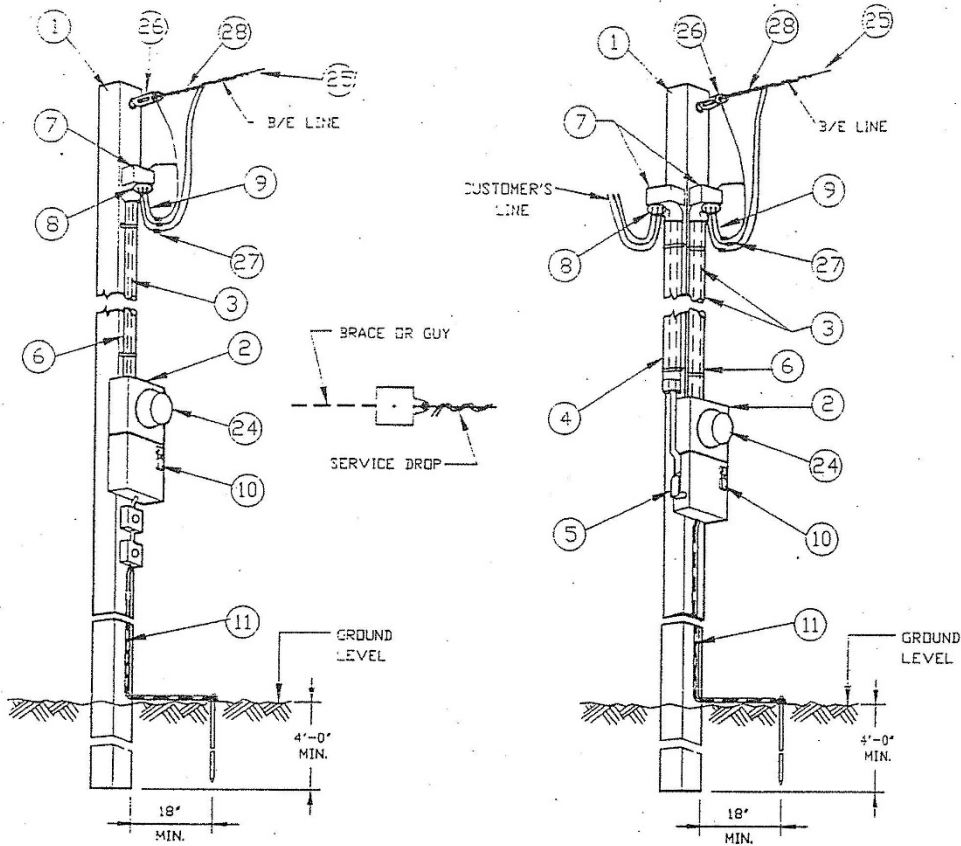

FIGURE V - 1(A)
SERVICE DROP CABLE
TO RECEPTACLES

FIGURE V - 1(B)
SERVICE DROP CABLE
TO OVERHEAD LINE

NOTES:

1. LOCATE BRACE OR GUY IN-LINE WITH SERVICE DROP.
2. GROUNDING, BY CUSTOMER, SHALL BE IN ACCORDANCE WITH N.E.C. AND LOCAL ORDINANCES, EXCEPT THAT THE GROUNDING WIRE SHALL BE PROTECTED AGAINST MECHANICAL DAMAGE BY RIGID STEEL CONDUIT OR #8 AWG MINIMUM ARMORED COPPER GROUND WIRE MAY BE USED.
3. CUSTOMER'S EQUIPMENT SHALL NOT BE INSTALLED IN CLIMBING SPACE..
4. FIG. V-1 (B) IS INTENDED TO SHOW EITHER TEMPORARY OR PERMANENT INSTALLATION WHERE SERVICE CONDUCTORS ENTER AND LEAVE THE POLE OVERHEAD.
5. RESIDENTIAL LOAD CENTER AND METER SOCKET COMBINATION MAY BE USED.
6. BY-PASS FACILITIES ARE NOT REQUIRED ON SINGLE-PHASE TEMPORARY SERVICES 200-AMPS OR LESS.
7. ALL 125-VOLT SINGLE-PHASE, 15-AMP AND 20-AMP RECEPTACLES SHALL BE GROUND-FAULT CIRCUIT PROTECTED.
8. SEE FIG. V-1 (C) FOR MATERIAL LIST.

**FIG. V - 1 (A) and (B)
APPROVED MINIMUM REQUIREMENTS FOR
TEMPORARY SERVICE POLES**

| MATERIALS TO BE FURNISHED AND INSTALLED BY THE CUSTOMER | |
|---|--|
| ITEM | DESCRIPTION |
| 1 | POLE, 6"x 6" TIMBER, LENGTH AS REQ'D. |
| 2 | METER SOCKET, MAIN SERVICE SWITCH |
| 3 | CONDUIT, SERVICE |
| 4 | CONDUIT, LOAD SIDE |
| 5 | CONDUIT FITTING, THREADED, WITH COVER AND GASKET |
| 6 | COVERING, WOOD OR FIBER CONDUIT WITH PLUMBER'S TAPE |
| 7 | WOOD BLOCK, 4"x 4"x 6" OR 2"x 4"x 6" NAILED TOGETHER |
| 8 | SERVICE HEAD |
| 9 | WIRE, INSULATED SIZE AS REQUIRED. (18" MINIMUM EXTENSION FROM SERVICE HEAD) |
| 10 | PADLOCK FOR MAIN SERVICE SWITCH |
| 11 | GROUNDING BY CUSTOMER |
| MATERIALS TO BE FURNISHED AND INSTALLED BY THE BUREAU | |
| 24 | METER, WATTHOUR, AS REQUIRED |
| 25 | SERVICE WIRE, AS REQUIRED |
| 26 | INSULATOR FOR SERVICE WIRE, AS REQUIRED |
| 27 | CONNECTORS, SERVICE SLEEVE, AS REQUIRED |
| 28 | PREFORMED GRIP, DEADEND, AS REQUIRED |

C:\ACAD\DCO\FIG5-1C 09-03-92

FIG. V - 1 (C)
APPROVED MINIMUM REQUIREMENTS FOR
TEMPORARY SERVICE POLES

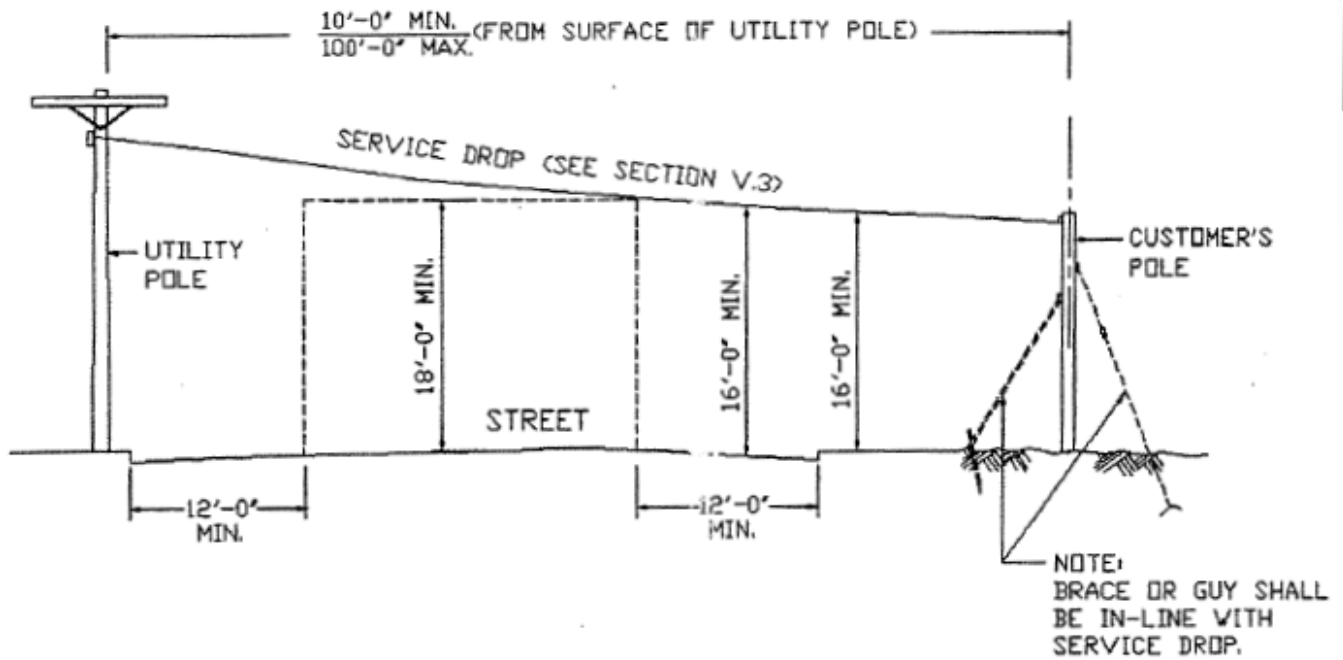
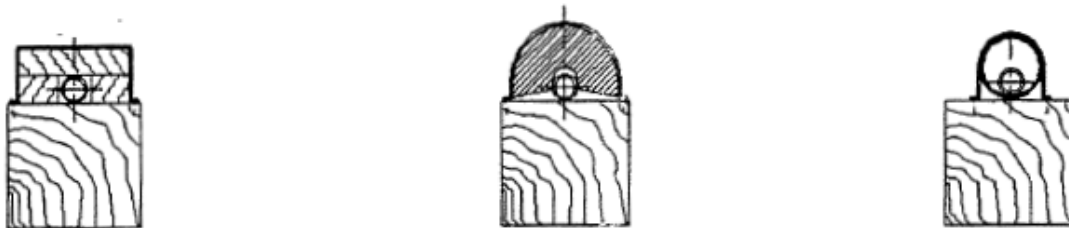

FIG. V - 2

CLEARANCES FOR SERVICE POLES



BOXING TO BE WOOD 1-1/2' MIN. THICKNESS. THE COVER TO BE NAILED TO THE SIDE PIECES. BOXING TO BE STRAPPED TO POLE WITH GALV. PERFORATED PLUMBER'S TAPE SPACED NOT OVER 3'-0' APART.

REDWOOD MOULDING 1-1/2' THICK STRAPPED TO POLE WITH GALV. PERFORATED PLUMBER'S TAPE SPACED NOT OVER 3'-0' APART.

FIBER CONDUIT OF 1/4' WALL THICKNESS OVER CONDUIT STRAPPED TO POLE WITH GALV. PERFORATED PLUMBER'S TAPE SPACED NOT OVER 3'-0' APART.

FIG. V - 3

METHODS OF COVERING CONDUITS